



Equipos y Maquinaria de  
Monterrey, S.A. de C.V.

# Vacuum dryers

---

## Vacuum shelf dryers

Model 438

9-2

---

## Conical vacuum dryers & SSP reactors

Model 159

9-3





## VACUUM SHELF DRYERS MODEL 438



Model 438 vacuum shelf dryers

BOC Edwards has over 90 years experience in the design of dryers for the chemical, pharmaceutical, plastics and metallurgical industries. BOC Edwards has pioneered the design of heated shelves for vacuum shelf dryers and developed the Solid State Polymerization reactor technology used in vacuum conical dryers worldwide.

### Model 438 shelf dryers

BOC Edwards Shelf Dryers provide rapid drying of heat sensitive, air sensitive, pyrophoric, and other materials that require drying without agitation. The dryer chamber features heated shelves (see below) which are sealed by use of an 'O' ring contained in a machined groove in the chamber door. The chamber assembly includes a vacuum break valve, vacuum gauge, a drain connection, and a connection for product thermocouples, and can be fitted with other connections as needed.

### Model 438 heated shelf design



One of the key design features of the Shelf Dryer is the shelf heating connection and manifold system. The supply and return tube for each shelf protrude through the back wall of the chamber where they connect to the supply and return header. Where each shelf exits the chamber, the tube is sealed with a proprietary tube ferrule sealing the chamber and assuring the vacuum integrity of the chamber. All shelf manifold connections are located outside of the drying chamber, eliminating any possible contamination of the product from leaks in the heating manifold.

An uppermost non-usable shelf is installed serving as the heating surface for the top of the chamber assembly. The shelves are constructed and inspected for maximum steam working pressure of 50 psig and are suitably baffled for efficient heating or cooling using water, oil, or steam.

### Model 438 specifications

- Non-code chamber with standard
- Heated shelves, 50 psi design pressure
- External manifolded shelf heating connections
- Door hinged with Viton® 'O' ring seal and clamps
- Sight glasses through door
- Vacuum gauge & 4 psi vacuum break valve
- Sloped bottom for draining, includes 1" NPT manual drain valve.

### Options

- Carbon steel, 316LSS, Hastelloy or special
- Internal finishes: #4 polish, Halar or PFA internal coating
- Wall flange
- Upgraded elastomers
- Insulation and SS sheathing
- Washdown duty
- Instrumentation
- Additional connections
- Door validation port
- Vacuum port location
- Product trays
- Vacuum System
- Heating System
- Control Panel

### Glovebox vacuum shelf dryers model 438GBX

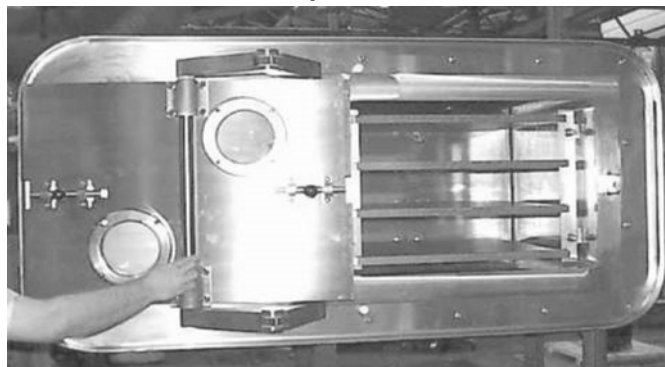

438GBX available in sizes B, D and F only.

BOC Edwards offers a "GBX" series vacuum shelf dryer to provide an air/liquid tight seal when mating to an isolation glove box. This design includes a spigot to accept an inflatable gasket seal from a portable glove box. The spigot is sealed to the chamber with a silicone gasket to ensure full isolation. The door hinges are a double articulating davited type design to keep the door swing within the parameters of the glove box.

### Model 438 sizes

CHAMBER SIZE		INTERNAL DIMENSIONS			SHELF SIZE W x D	USEABLE SHELVES
		WIDTH	DEPTH	HEIGHT		
438 B	Stock	30"	29"	20.5"	24" X 24"	up to 6
438 D	Stock	30"	42"	27"	24" X 36"	up to 9
438 F		30"	42"	39"	24" X 36"	up to 12
438 H	Stock	50"	46"	49"	44" X 40"	up to 15
438 J		50"	46"	71.5"	44" X 40"	up to 22



## CONICAL VACUUM DRYERS & SSP REACTORS MODEL 159



MODEL	NOMINAL WORKING CAPACITY ft <sup>3</sup>	HP	TOTAL WEIGHT EMPTY (lbs)	RPM
159-1	3	0.5	1600	6
159-2	10	0.75	2000	6
159-3	25	2	4000	6
159-4	50	5	4500	6
159-5	75	7.5	6000	6
159-6	100	10	8500	6
159-7	150	10	12000	6
159-8	250	*	20000	3
159-9	325	*	22000	3
159-10	400	15	24000	2
159-12	500	*	37000	2
159-14	775	40	57400	2
159-15	1000	60	*	2

\* contact product marketing

### Conical rotating vacuum dryer systems

Conical vacuum dryers deliver gentle, uniform drying at low temperatures and eliminate the contaminating and destructive effects of air drying. These drying systems are ideal for powders, crystalline or heat sensitive materials that need to be dried without excessive agitation.

### PET solid-state reactor systems

BOC Edwards is the preferred equipment supplier of the plastics industry for solid state polymerization (SSP). SSP systems are sold as complete packaged systems to improve product uniformity and dramatically shorten cycle times in processing of PET, PEN, nylon and other polymers. As batch systems, they offer significant advantages over continuous solid-stating techniques. These include easier switches from one product to another, and easier specification changes for processing a single polymer, in order to achieve the various molecular weights (intrinsic viscosity) required for different end users.

The unique Plus-Surface design is an extended heating surface concept which significantly improves heating surface/volume ratio. Plus-Surface results in 115% more "wetted" heat transfer area while sacrificing only 6% of working volume. Plus-Surface is a distinct advantage to polymer processors since it dramatically reduces cycle times and enhances mixing characteristics to ensure product uniformity.

### Rugged, durable operating features:

- Closely controlled temperature capability
- Unique Plus-Surface design
- Patented internal design
- Large diameter straight cylinder design with beveled closure plates
- Standard 304SS construction
- Easy loading/unloading
- Easy servicing/cleaning
- High reliability
- Internal stainless steel filter
- Variable speed drive

### Options

- Alternate material of construction
- High pressure rated jacket
- Insulation and sheathing
- Polished internal surfaces
- Internal thermocouple
- Nitrogen sweep
- Air operated discharge valve
- Charge/discharge positioning

### Model 159 schematic

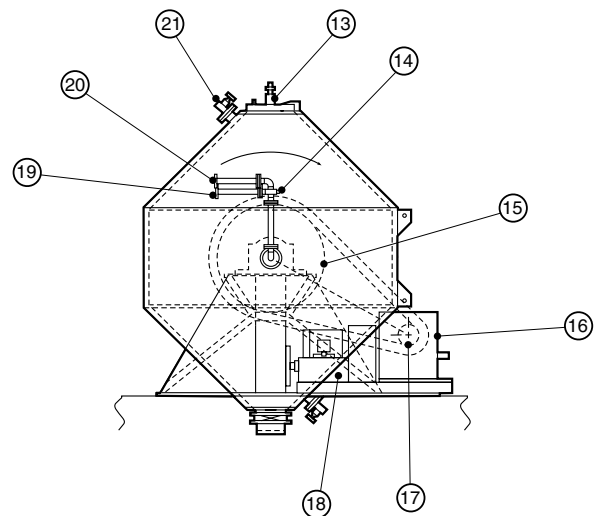
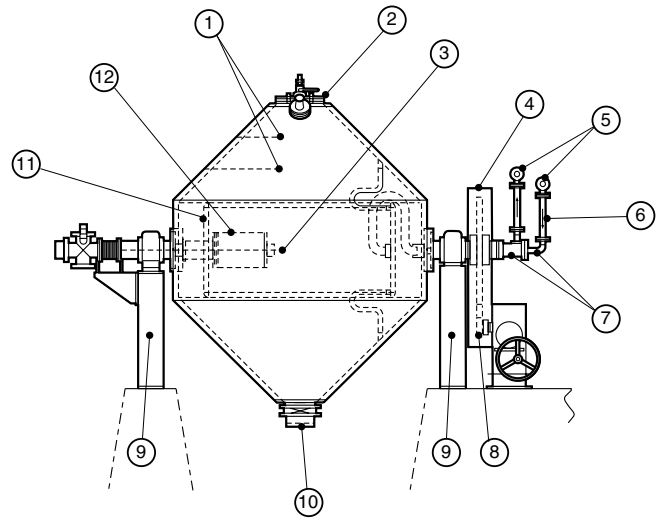

- |  |   |
|--|---|
| 1 Hot oil baffles                            | 12 Product baffle                                       |
| 2 18" Clear dia. charging opening with cover | 13 Sampling ARRGT                                       |
| 3 T/C Probe                                  | 14 Thermowell for hot oil inlet temperature measurement |
| 4 Oil tight chain casing                     | 15 Driven sprocket                                      |
| 5 2" N.P.S. connections                      | 16 Standard drive                                       |
| 6 Flexible metal hoses                       | 17 Drive sprocket                                       |
| 7 Hot oil connections                        | 18 15 H.P. motor  |
| 8 Drive unit                                 | 19 Oil inlet  |
| 9 End frame and bearing                      | 20 Oil outlet   |
| 10 Discharge port                            | 21 Forged steel gate valve                              |
| 11 Heating surface                           |   |



## **Auxiliary dryer components**

**Vacuum pumping systems** BOC Edwards offers custom-engineered mechanical, liquid ring or completely dry-running pumps depending on your application. Condensers are also available for large vapor loads or solvent recovery.

**Heating systems** Heating packages come complete as electric, gas fired or steam heated systems using water, water/glycol or oil as the heating medium. Heating packages can be stand alone units serving one dryer each or one large central heater with several satellite circulation skids per dryer.

**Control packages** Dryers offer a wide range of control systems and features the use of SCADA packages with distributed I/O hardware. This allows for complete data acquisition of all information that a customer may require.